

Mori-Say Clamping Collets

Code	Description	d	D	L	a	Thread (F)	Diameter max	Hex max
9012E	6/20	34.0	42.0	90.0	16°	M30X1 Left	24.0	19.0
9034E	6/25-626	41.3	54.5	132.0	15°	Ø37,8 X 24 Left	30.0	24.0
9069E	6/32-8/32 Type Gildemeister	53.0	69.4	139.0	15°	M48X1.5 Left	38.0	31.0
9070E	6/32-8/32 Type Schütte	53.0	69.3	136.5	15°	M47X1.5 Left	38.0	32.0
9112E	6/42-8/42 Type Schütte	62.9	78.3	157.0	15°	M56X1.5 Left	49.0	41.0
9142E	6/57	76.86	95.5	181.0	15°	Ø72,46 X 22 Left	62.0	53.0
9181E	6/67	92.07	111.0	165.0	15°	Ø85,72 X 18 Left	77.0	65.0

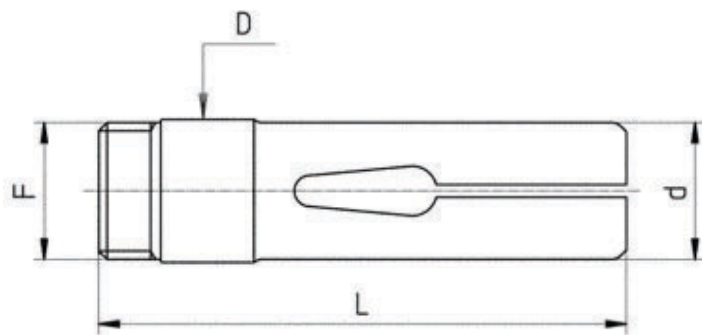

Mori-Say Feed Fingers

Code	Description	d	D	L	Thread (F)	Diameter max	Hex max
9258E	6/20	25.0	25.0	90.0	M24X1	20.0	17.0
9276E	6/25-626	31.0	31.9	133.0	Ø30,07 X 24 Left	25.0	22.0
9319E	6/32-8/32 Type Schütte	40.0	42.0	130.0	M38X1.5	32.0	28.0
9336E	6/32-8/32 Type Gild.	39.8	41.2	136.0	M38X1.5 Left	32.0	28.0
9372E	6/42-8/42 Type Schütte	48.0	51.0	158.0	M48X1.5	42.0	36.0
9409E	6/57	64.3	65.0	171.5	Ø65,509 X 22 Left	57.0	49.0
9445E	6/67	74.0	76.0	179.0	Ø73 X 24 Left	66.0	47.0